

TC-YS VALVE

800 WOG Y STRAINER, THREADED, SOCKET-WELD



DESIGN FEATURES:

- Body: ASTM A351 Gr.CF8M
- Screen: SS316
- Packing: PTFE.
- Working Pressure: 800 psi
- TEST STANDARD: API 598
- End Connections: Threaded End
Socket-Weld End
- Threaded Type:
ANSI B1.20.1 (NPT)
DIN 259 / DIN 2999
ISO 228
BSP
PT

MATERIALS LIST

| NO | PARTS NAME | SPECIFICATION | Q, TY |
|----|-------------|---------------------|-------|
| 1 | BODY | ASTM A-351 Gr. CF8M | 1 |
| 2 | SCREEN | 1mm holes | 1 |
| 3 | GASKET | PTFE | 1 |
| 4 | BONNET | ASTM A-351 Gr. CF8M | 1 |
| 5 | PLUG GASKET | PTFE | 1 |
| 6 | PLUG | ASTM A-351 Gr. CF8M | 1 |

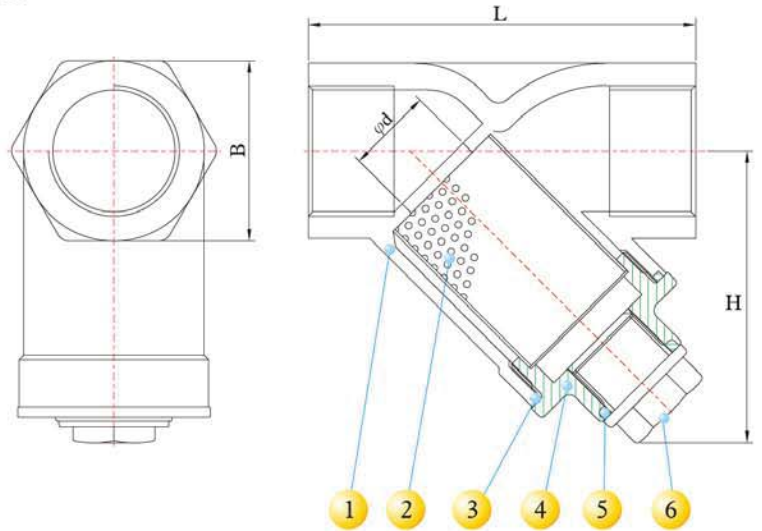

PRESSURE TEMPERATURE RATINGS

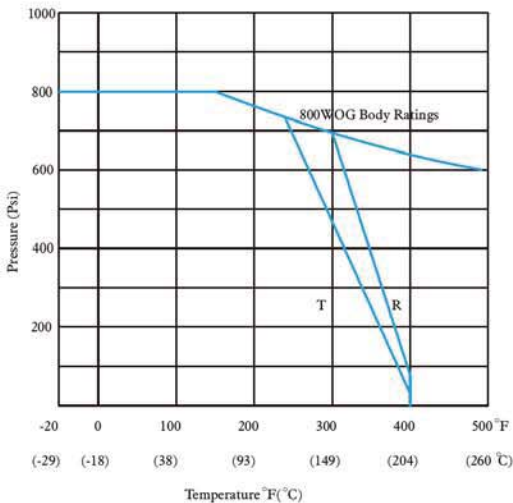

DIMENSIONS

| SIZE | | d | | B | | H | | L | | Weight | |
|--------|----|------|----|------|-----|------|-----|------|-----|--------|-------|
| inch | mm | inch | mm | inch | mm | inch | mm | inch | mm | Kg | Lb |
| 1/4" | 8 | 0.43 | 11 | 0.91 | 23 | 1.81 | 46 | 2.56 | 65 | 0.24 | 0.53 |
| 3/8" | 10 | 0.51 | 13 | 0.91 | 23 | 1.81 | 46 | 2.56 | 65 | 0.23 | 0.5 |
| 1/2" | 15 | 0.59 | 15 | 1.02 | 26 | 1.81 | 46 | 2.56 | 65 | 0.23 | 0.5 |
| 3/4" | 20 | 0.79 | 20 | 1.26 | 32 | 2.17 | 55 | 3.15 | 80 | 0.36 | 0.79 |
| 1" | 25 | 0.98 | 25 | 1.61 | 41 | 2.76 | 70 | 3.54 | 90 | 0.70 | 1.54 |
| 1-1/4" | 32 | 1.26 | 32 | 2.01 | 51 | 2.87 | 73 | 4.13 | 105 | 0.90 | 1.98 |
| 1-1/2" | 40 | 1.57 | 40 | 2.24 | 57 | 3.19 | 81 | 4.72 | 120 | 1.20 | 2.64 |
| 2" | 50 | 1.97 | 50 | 2.72 | 69 | 3.70 | 94 | 5.51 | 140 | 1.90 | 4.19 |
| 2-1/2" | 65 | 2.56 | 65 | 3.43 | 87 | 4.72 | 120 | 6.69 | 170 | 4.30 | 9.47 |
| 3" | 80 | 3.15 | 80 | 4.02 | 102 | 5.51 | 140 | 7.87 | 200 | 6.30 | 13.88 |

Y STRAINER

SCREEN FOR TC-YS / TC-YSF (Y STRAINER)



If you need spare screens for our strainers, we can supply exact replacements, please contact us directly.

--

If you need a different size mesh or perforated screen, or a different screen material than what we offer in our strainers, click here. They can make almost any type of screen that you need, custom made to fit our strainers. Send them this drawing and ask them directly for a quote on the type of screens you need.

● Material:SS316

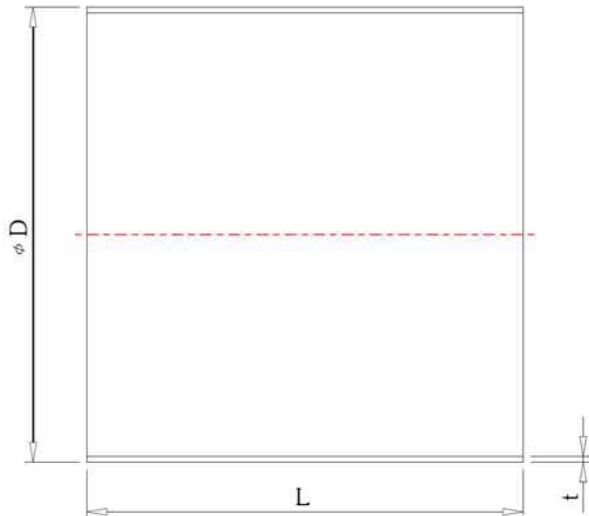

TC-YS 800 WOG THREADED, SOCKET-WELD Y STRAINER

DIMENSIONS

| SIZE | D | | L | | W | | d | | t | |
|----------------|-------|----|-------|------|-------|----|-------|----|-------|-----|
| inch | inch | mm | inch | mm | inch | mm | inch | mm | inch | mm |
| 1/4",3/8",1/2" | 0.787 | 20 | 1.102 | 28.0 | 0.079 | 2 | 0.039 | 1 | 0.016 | 0.4 |
| 3/4" | 0.984 | 25 | 1.535 | 39.0 | 0.079 | 2 | 0.039 | 1 | 0.016 | 0.4 |
| 1" | 1.260 | 32 | 1.890 | 48.0 | 0.079 | 2 | 0.039 | 1 | 0.016 | 0.4 |
| 1-1/4" | 1.496 | 38 | 2.087 | 53.0 | 0.079 | 2 | 0.039 | 1 | 0.016 | 0.4 |
| 1-1/2" | 1.732 | 44 | 2.461 | 62.5 | 0.079 | 2 | 0.039 | 1 | 0.016 | 0.4 |
| 2" | 2.205 | 56 | 2.953 | 75.0 | 0.079 | 2 | 0.039 | 1 | 0.016 | 0.4 |
| 2-1/2" | 2.874 | 73 | 3.543 | 90.0 | 0.079 | 2 | 0.039 | 1 | 0.016 | 0.4 |
| 3" | 3.465 | 88 | 3.898 | 99.0 | 0.079 | 2 | 0.039 | 1 | 0.016 | 0.4 |

● Material:SS316

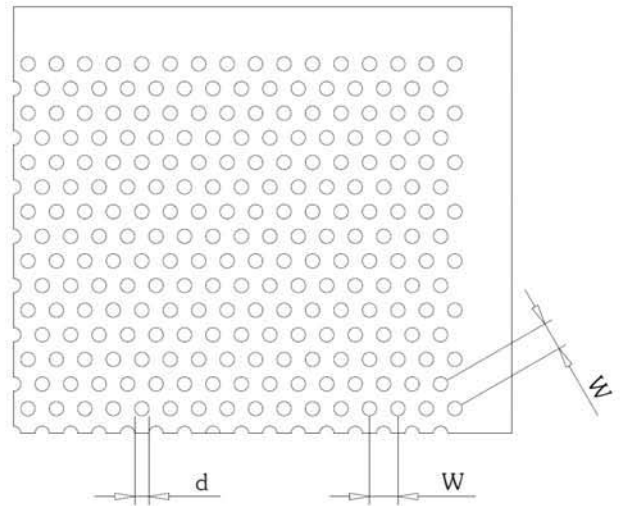

TC-YSF 150# R.F. FLANGED Y STRAINERS

DIMENSIONS

| SIZE | D | | L | | W | | d | | t | |
|--------|-------|-----|--------|-------|-------|----|-------|----|-------|-----|
| inch | inch | mm | inch | mm | inch | mm | inch | mm | inch | mm |
| 2" | 1.890 | 48 | 4.409 | 112.0 | 0.079 | 2 | 0.039 | 1 | 0.020 | 0.5 |
| 2-1/2" | 2.480 | 63 | 5.906 | 150.0 | 0.079 | 2 | 0.039 | 1 | 0.020 | 0.5 |
| 3" | 3.189 | 81 | 6.457 | 164.0 | 0.079 | 2 | 0.039 | 1 | 0.020 | 0.5 |
| 4" | 3.622 | 92 | 7.717 | 196.0 | 0.079 | 2 | 0.039 | 1 | 0.031 | 0.8 |
| 6" | 5.906 | 150 | 11.417 | 290.0 | 0.197 | 5 | 0.118 | 3 | 0.039 | 1.0 |