

# FORGED BRASS BALL VALVES

# DISCOVER VALVE

2-PIECE, FORGED BRASS, FULL PORT, THREADED (1/4" to 2" with CSA and NSF61 approvals) AND SOLDER ENDS (1/2" to 2" with NSF61 approvals), 600WOG /150SWP TO 2" (2-1/2" TO 4" 400WOG/125SWP), DOUBLE O-RING DESIGN, VALVES CONFORM TO FEDERAL SPECIFICATION WW-V-35, TYPE II CLASS A, STYLE 3 AND MSS-SP-110.

CSA APPROVAL  
NSF 61 APPROVAL

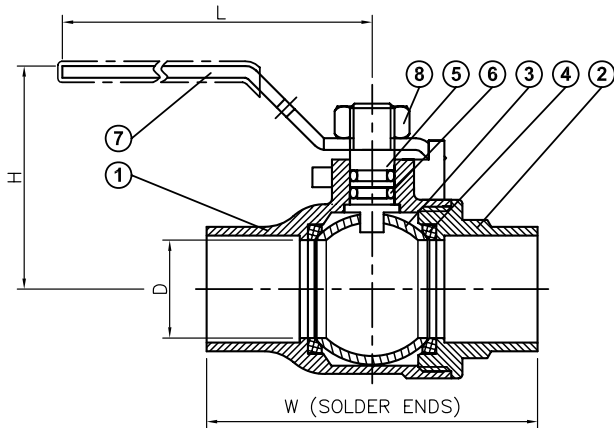
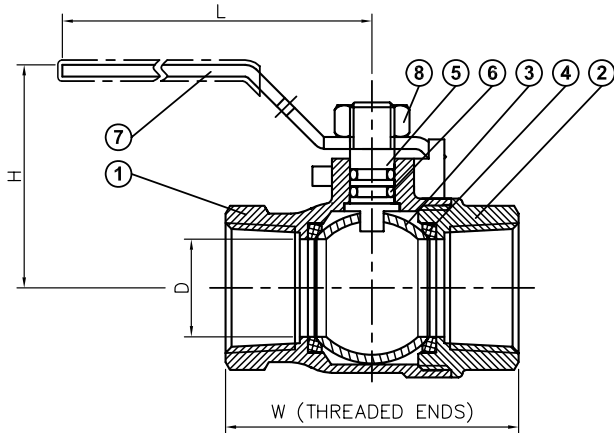

### MATERIALS LIST:

NO.	PART	SPECIFICATION
1	BODY	FORGED BRASS
2	END CAP	FORGED BRASS
3	BALL	COPPER ALLOY, CHROME PLATED
4	SEAT	PTFE
5	STEM	COPPER ALLOY
6	O-RING	VITON
7	HANDLE	CARBON STEEL PLATED
8	NUT	CARBON STEEL PLATED

### OPTION: (Code: Description)

AG: Locking Handle  
TH: Hollow Ball



### DIMENSIONS:

SIZE		D		W				H		L	
				THREADED ENDS		SOLDER ENDS					
IN	MM	IN	MM	IN	MM	IN	MM	IN	MM	IN	MM
1/4"	8.0	0.31	8.0	1.49	37.8	-	-	1.11	28.2	3.23	82.0
3/8"	10.0	0.31	8.0	1.63	41.5	-	-	1.11	28.2	3.23	82.0
1/2"	15.0	0.44	11.2	1.98	50.3	1.89	47.9	1.13	28.8	3.23	82.0
3/4"	20.0	0.69	17.6	2.29	58.1	2.67	67.9	1.58	40.2	3.94	100.0
1"	25.0	0.94	24.0	2.80	71.0	3.30	83.9	1.96	49.8	4.72	120.0
1-1/4"	32.0	1.19	30.3	3.19	81.0	3.78	96.1	2.14	54.4	4.72	120.0
1-1/2"	40.0	1.44	36.6	3.45	87.6	4.30	109.2	2.54	64.4	7.09	160.0
2"	50.0	1.94	49.3	4.03	102.3	5.33	135.3	2.89	73.3	7.09	160.0
2-1/2"	65.0	2.44	62.0	5.09	129.4	6.22	158.0	4.06	103.0	8.66	220.0
3"	80.0	2.94	74.7	5.78	146.9	7.09	180.2	4.49	114.1	8.66	220.0
4"	100.0	3.94	100.1	7.01	178.1	9.19	233.5	5.26	133.5	9.84	250.0

"Above port size dimension meets full port standard per MSS-SP-110"

DUE TO CONTINUOUS DEVELOPMENT OF OUR PRODUCTS, WE RESERVE THE RIGHT TO MODIFY OUR PRODUCT DESIGN OR CONSTRUCTION WITHOUT PRIOR NOTICE.